

Product No. **7244-510-12**
 S No. **4112868**
 EAN No. **7312907244320**



Opus 120/200

Open 120 is an elegant cylindrical shaped light fitting. Its timeless design is suitable for wall or ceiling installation, both indoors and outdoors. Opus 120 is available with a matt opal or clear glass shade.

Specification

Base material	Porcelain
Lampholder	E27
Light source	Max 75W (not incl.)
Voltage	230V
Installation	Ceiling/wall
Base colour	Grey NCS S 6005-G50Y
Safety class	II
Protection class	IP54
Energy class	-
T _a	-30 - +25
Height	204 mm
Diameter Ø	116 mm
Glass	Clear glass
Thread	99 mm
Weight	1,4 kg
Design	Duoform

Installation

Insert the mains supply cable through the bottom inlet. Push the silicone sleeves included over the leads. Fix the light fitting to the wall or to the ceiling with suitable screws. Connect the leads to the mantle screws. Fasten the lamp holder. Insert a light source and then fasten the shade by turning it clockwise. Make sure the gasket between the glass and base is in place.

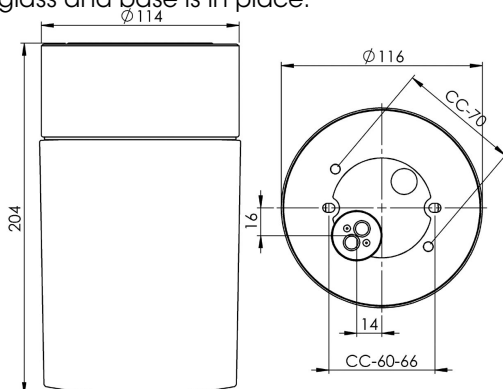

Technical information

Silicone gasket between glass and base. Four Ø 5mm holes for installation. Two holes CC measurement 60-66 mm, alternatively two hidden holes CC measurement 70 mm. One bottom inlet for two mains supply cable. Two mantle screws for connection of max 2 x 2,5 mm². Bridging is possible. Bottom inlet. No knock out openings. The shade is hand-blown, therefore they are all unique, minor variations may occur.

Maintenance

Switch off the power to the fixture. Remove the shade and clean it. Do not use cleaning agents containing solvents. Change the light source if necessary. Check the gasket and change it if necessary. Replace the shade.

Spare parts

Shade: Part no 1-6184-10
 Gasket: Part no 03542

If the luminaire is modified the person responsible for the modification shall be considered manufacturer. Subject to errors in text. We reserve the right to change the technical specifications (without notice).